

**Turbo Technics Ltd.**

2 Sketty Close, Brackmills, Northampton. NN4 7PL. U.K.  
Tel: +44 1604 705050 Fax: +44 1604 769668  
Internet: www.turbotechnics.com  
e-mail: vsr@turbotechnics.com



**INTRODUCTION TO THE PRINCIPLES OF TURBOCHARGER**  
**CORE BALANCING USING THE TURBO TECHNICS VSR**

Turbochargers are assembled from component parts, which are separately balanced using conventional low-speed, component balancing machines, and both the turbine wheel, and compressor wheel are normally balanced separately in two planes. At the turbine end, the balance is not affected by assembly into the cartridge, but at the compressor end, small errors in the shaft, the compressor wheel, the thrust collar, and the nose nut can cause an accumulation of balance error. At high speed, this can result in a noisy turbocharger, and in a severe case can cause premature bearing failure.

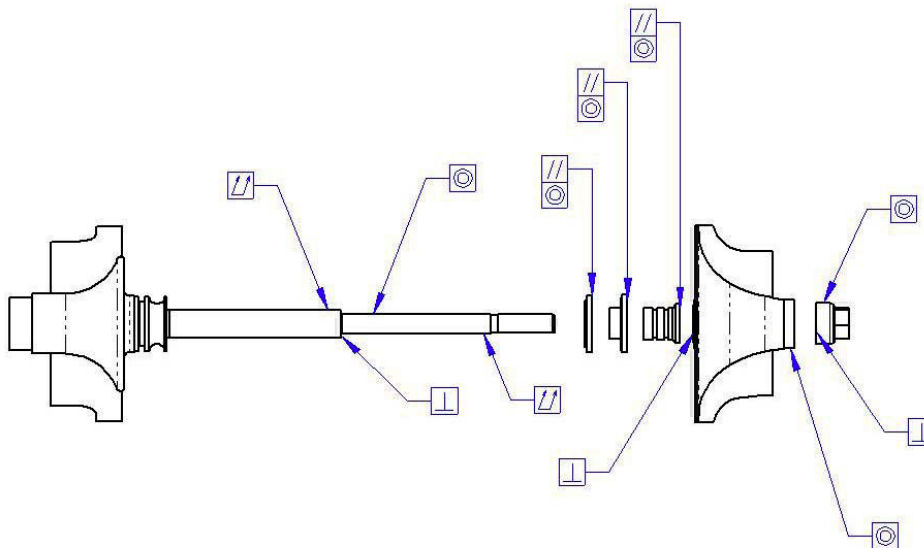

**TYPICAL ROTOR ASSEMBLY**  
**POSSIBLE ERRORS AFFECTING BALANCE**

The rotor system imbalance can be corrected by running the assembled cartridge at high speed on a flexible suspension, measuring the vibration response, and either changing the assembly position or removing metal from the nose to achieve an acceptable balance. This operation usually requires the unit to be run at speeds close to the normal service operating speed, typically 100,000 to 200,000 rev/min, depending on wheel size. Conventional practice is to remove material from the nose nut to achieve an acceptable vibration level.

**Turbo Technics Ltd.**

2 Sketty Close, Brackmills, Northampton. NN4 7PL. U.K.  
Tel: +44 1604 705050 Fax: +44 1604 769668  
Internet: www.turbotechnics.com  
e-mail: vsr@turbotechnics.com



**BALANCING PRACTICE**

In operation, the CHRA is mounted in a slave turbine housing adapter, using quick-release clamps to hold it. The turbine housing is in turn attached to a flexibly-mounted air nozzle assembly, which directs air into the housing, rotating the turbine shaft. An accelerometer attached to the flange measures the vibration of the complete assembly.

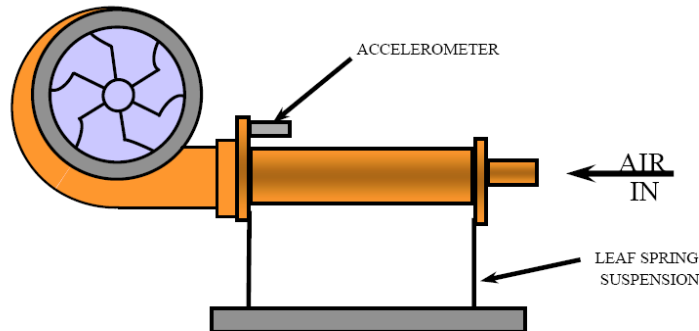

The admission of air to the turbine is controlled, allowing the CHRA to be accelerated slowly across the speed range.

The compressor wheel is covered by a shroud for safety, and to reduce air 'windage'. The nose nut or shaft end is magnetised, and a coil in the centre of the shroud converts the rotation of the magnetic field into a voltage signal, which is processed internally as a speed signal.

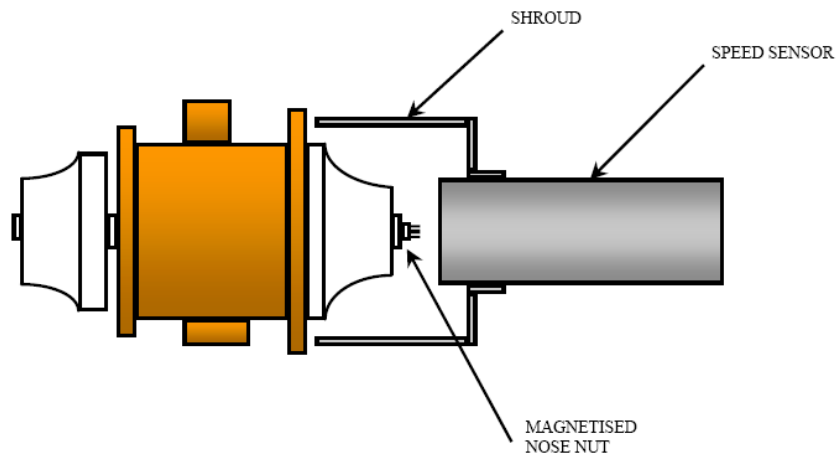

**Turbo Technics Ltd.**

2 Sketty Close, Brackmills, Northampton. NN4 7PL. U.K.  
Tel: +44 1604 705050 Fax: +44 1604 769668  
Internet: www.turbotechnics.com  
e-mail: vsr@turbotechnics.com



For balancing purposes, only the vibration signal at the rotational speed is of interest. The accelerometer and speed signals are therefore processed electronically to remove unwanted frequencies, giving a display of vibration level (g-level) against speed as the CHRA is accelerated up to the maximum speed. At the same time, the angular difference between the speed signal and the accelerometer signal is displayed (the 'clock' position) to indicate the imbalance position for correction.

The typical response of a turbocharger rotating assembly will normally exhibit two peaks, or resonances, as shown and the apparent 'clock' position will change with speed.

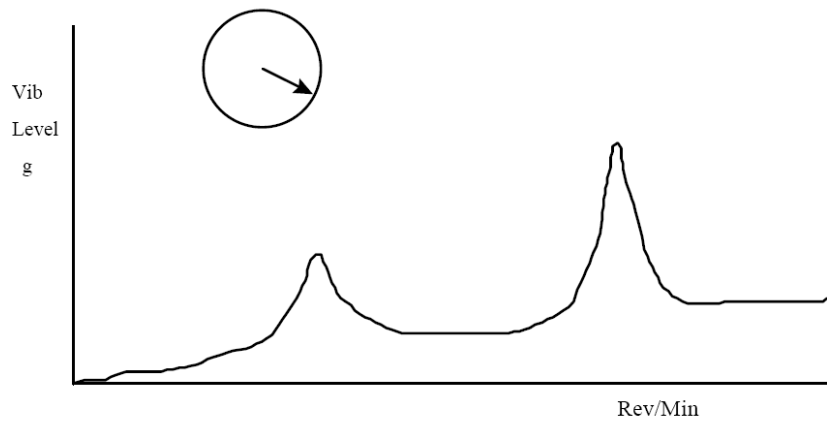

By moving the cursor to a selected speed point, the imbalance position at that speed can be displayed, and material removed to achieve a desired balance level.

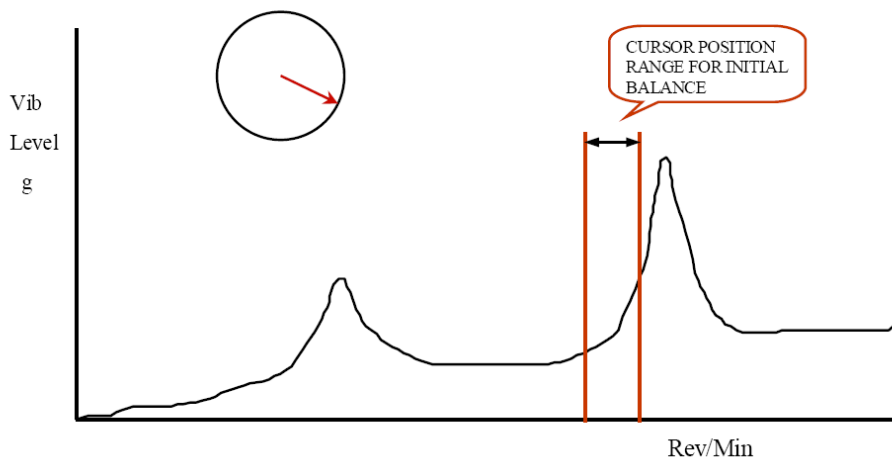

Note: the clock position is used differently between different versions of VSR, and the instructions relating to the particular model type should be followed.

**Turbo Technics Ltd.**

2 Sketty Close, Brackmills, Northampton. NN4 7PL. U.K.  
Tel: +44 1604 705050 Fax: +44 1604 769668  
Internet: www.turbotechnics.com  
e-mail: vsr@turbotechnics.com



On occasion, it may be found that a core can be balanced at either low speed or high speed, but cannot be balanced at all speeds. The typical symptom is that attempts to improve balance at high speed produce a worsening of balance at low speed, or the 'heavy' point changes angle. This is most commonly a symptom of either a compressor wheel that is badly balanced on the back disc, or a stub-shaft that is not concentric. In this situation, the balance error at the back-disc can be corrected at the nose while the shaft is rigid and straight at low speeds, but higher rotational speeds cause the shaft to bend, and destroy the balance. In this situation, the compressor wheel must be balanced separately, or the SWA corrected.

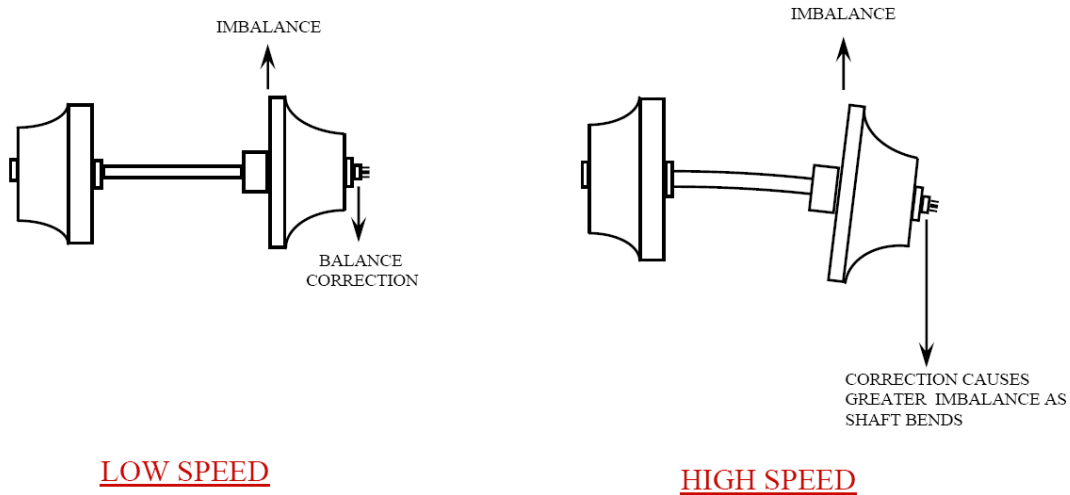

An indication of this problem can be obtained by observing the 'clock' during the initial balancing phase. With two cursors set as shown in the diagram, balance vector reference positions which are opposite will be difficult to balance. In this situation, the best approach will be to rotate the impeller to bring the vectors in line before making balance cuts.

**Turbo Technics Ltd.**

2 Sketty Close, Brackmills, Northampton. NN4 7PL. U.K.  
Tel: +44 1604 705050 Fax: +44 1604 769668  
Internet: www.turbotechnics.com  
e-mail: vsr@turbotechnics.com



**ADVANCED BALANCING METHOD**

(Note: It is recommended that a new operator should become familiar with the basic method of balancing before proceeding to this section)

A refinement of the technique, which is applicable to some turbo types, allows the compressor wheel to be balanced in two planes on the VSR. The technique is to balance the rotating assembly, at the higher speed peak only, by removing metal from the nose nut in the normal manner until a satisfactory balance is achieved, ignoring the lower speed peak. The assembly is then balanced at lower speeds by removing metal from the back disc of the compressor wheel between the blades,

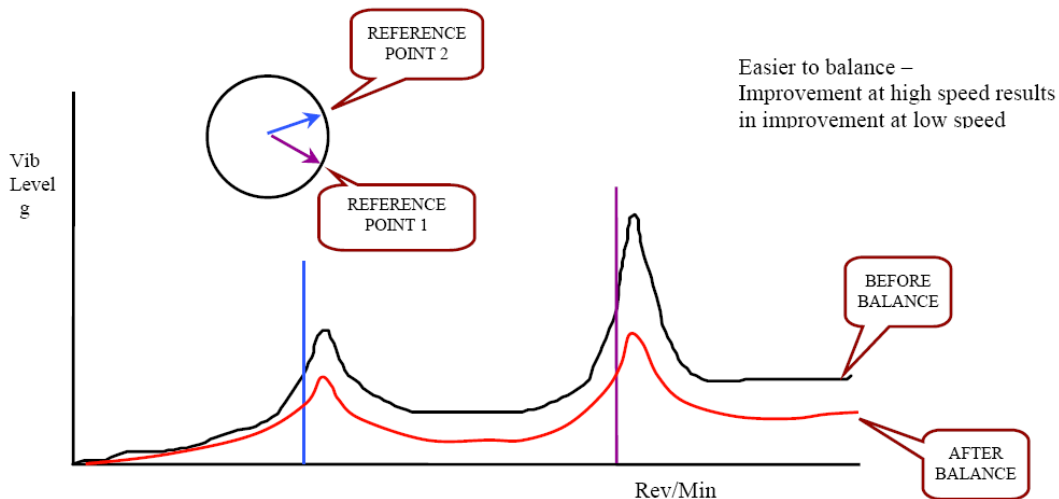
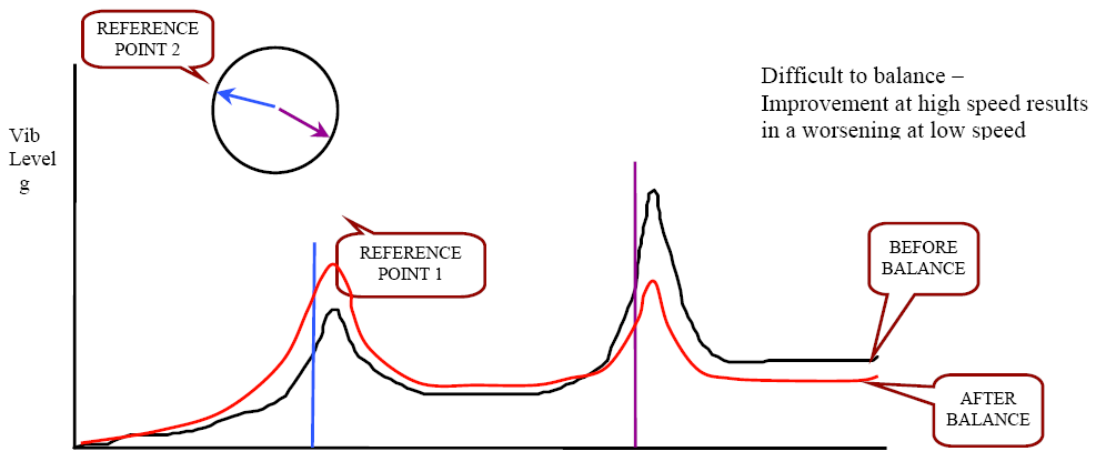

using a small burr (a hand-held Dremel is useful for this). The 'clock' positions are used in the normal manner for this process. This back disc balancing technique will normally have very little effect on the high-speed balance, but this should be finally checked. However, balance cuts should be kept very shallow to avoid weakening the wheel.

**Turbo Technics Ltd.**

2 Sketty Close, Brackmills, Northampton. NN4 7PL. U.K.  
Tel: +44 1604 705050 Fax: +44 1604 769668  
Internet: www.turbotechnics.com  
e-mail: vsr@turbotechnics.com



**BALANCING SPEED**

The balancing process does not normally require running to the maximum speed, and the rotational speed should only approach these limits in exceptional cases. In general, it is only necessary to run the core to sufficient speed to cover the first and second resonance points, and running beyond this will not normally serve any useful purpose. Running a turbo core at excessive speed can be dangerous. Compressor wheels can burst, causing major damage and danger to personnel.

In most cases, the turbocharger manufacturer will specify a maximum speed for balancing, and this should always be respected. However, in some instances this information may not be available, and the following graph can be used as a guide to the maximum safe operating speed for the core, based on compressor wheel size. These values should be used with caution.

**VSR – Guide to max rotational speed**

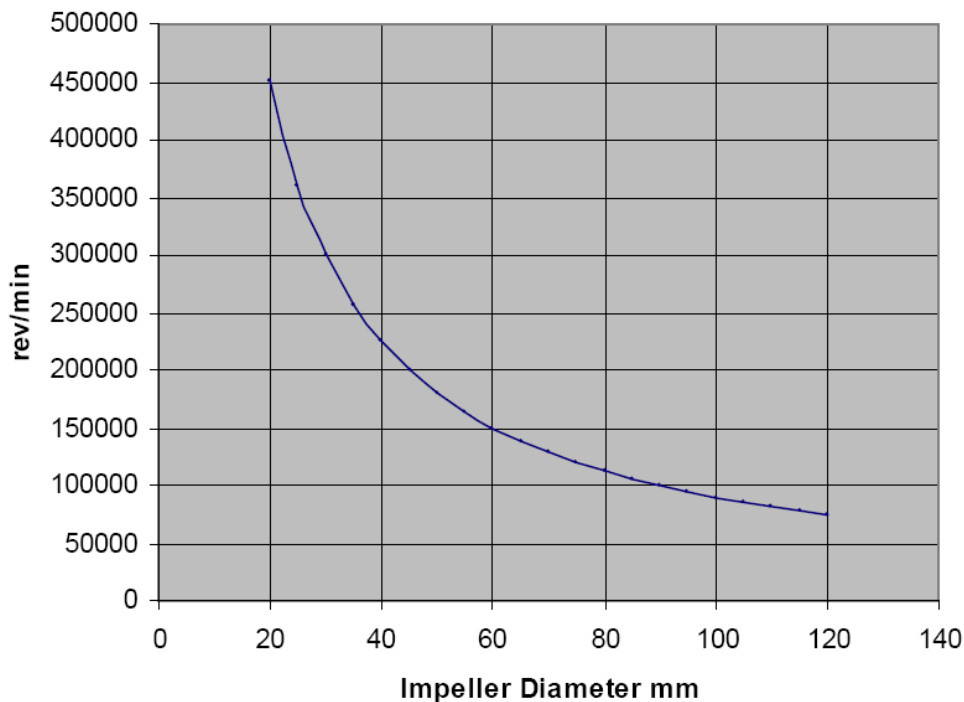

The graph gives a guide to the maximum safe speed for good quality impellers of modern design and construction